

ISO13485:2016
CERTIFIED

ISO 9001:2015
CERTIFIED



User Instructions

Para ver las instrucciones de uso en español visita www.homscales.com

Pour les instructions de l'utilisateur dans la visite française

www.homscales.com



PELSTAR, LLC 9500 West 55th St. McCook, IL 60525-7110 USA

www.homscales.com

Health o meter® Professional 1522KL

© Pelstar, LLC 2025

Introduction

The 1522KL Mechanical Baby Scale provides precise weighing of babies and toddlers. It is durable, having a sturdy enameled steel body and a wipe down, thermoformed plastic weighing tray with measuring ruler. These installation and operating instructions will guide the user through basic instructions on pillar assembly, plastic weighing tray installation and the zero adjustment of the scale.

Specifications

Model	1522KL
Capacities	135lbx1oz / 62kgx20g;
Weighing Tray Size	610x373mm; 24"x14.7"
Overall dimension (LxWxH)	610x530x686mm; 24"x20.9"x27"

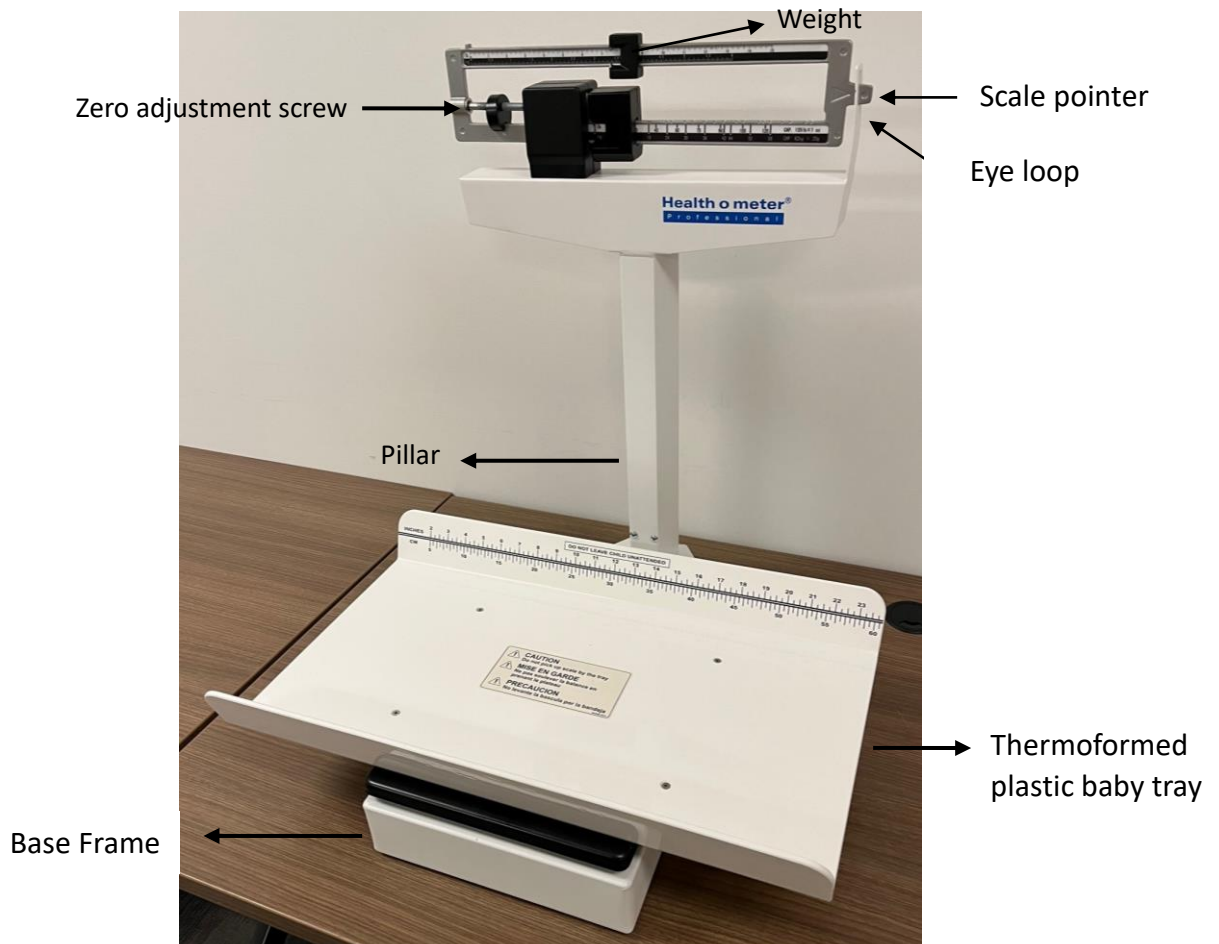

Installation Instructions

The following components are required assembly:

- Pillar assembly
- Steelyard rod connection
- Molded plastic weighing tray assembly

Remove all components from the shipping box and lay out in a convenient place.

▪ Pillar Installation

Prior to assembly, you will need the following tools to finish assembling the EL-BS Mechanical Baby Scale.

- Philips head screwdriver
- Multi-purpose tool (included)

The pillar comes separate from the scale base and must be attached prior to use. Use the following steps to attach the pillar to the scale base.

1. Set the scale base on a table or other convenient place with the bottom facing upwards (shown in left side photo in Figure 2-1)
2. Remove twisty tie off of the scale base as shown on the left hand side of Figure 2-1. Remove the cable tie that holds the steelyard rod from shifting during transit (shown in right side of Figure 2-1.)

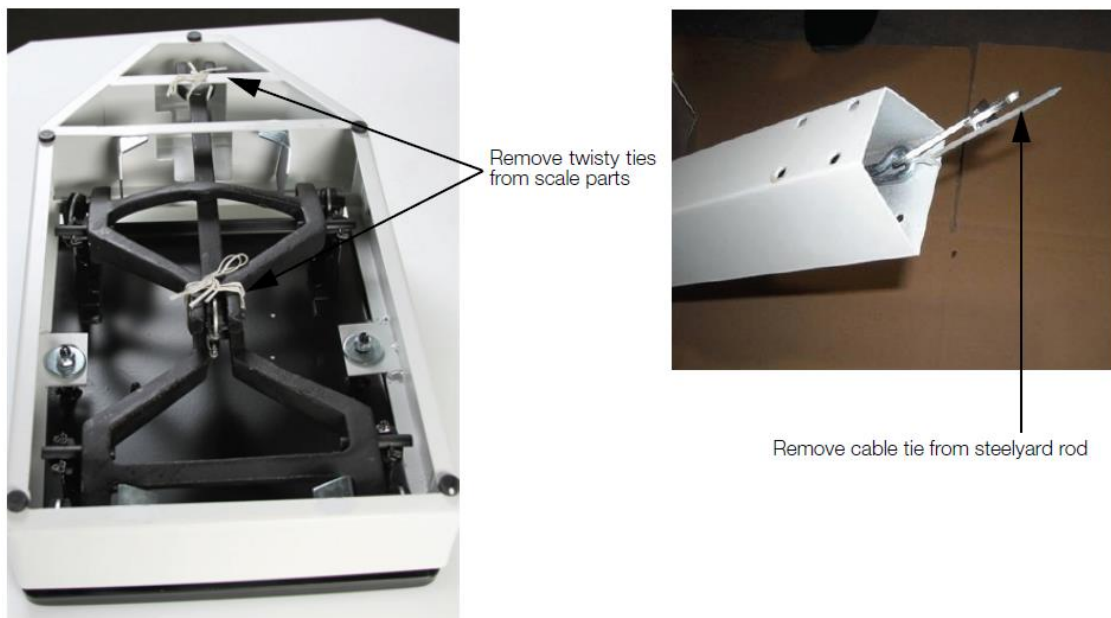

Figure 2-1. Remove Cable Ties and Cable Ties

3. Insert the pillar into the scale base assembly ensuring that the MEASURETEK logo located on the weigh beam faces the scale base.

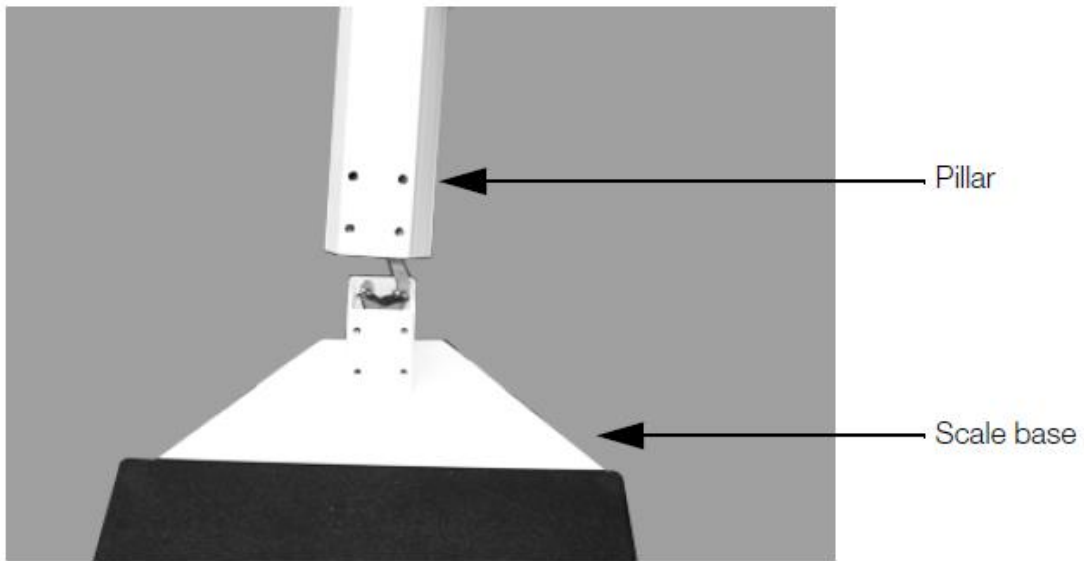

Figure 2-2. Attach the Pillar to the Scale Base

4. Using a Philips head screwdriver, screw in the eight bolts and washers to secure the pillar to scale base.



Figure 2-3. Attach Eight Bolts and Washers to Secure the Pillar to the Scale Base

▪ **Steelyard Rod Connection**

The steelyard rod is located inside the scale pillar. Once the pillar is attached to the scale base, the steelyard rod must be attached to the bottom of the scale.

1. Lay the scale pillar on a table so that the scale platform hangs over the edge of the table and allows you to access the bottom of the scale.

2. Insert the hook part of the multi-purpose tool (included and shown below) into the small hole in bottom of the steelyard rod and pull the hook of the steelyard rod with the hook of the multi-purpose tool to connect it to the scale base lever as shown in Figure 2-4 then push the scale base lever towards the pillar head and hook the bearing of the steelyard rod on the pivot of the long lever.



Figure 2-4. Connecting the Steelyard Rod to the Scale Base

NOTE: Visually ensure that the force lever assembly linkage (shown in Figure2-5) is centered and properly aligned. Occasionally during shipping, the alignment will become skewed. The linkage must be free floating in order for the scale to weigh properly. The linkage can be seen by looking up underneath the top weigh beam if the scale is slightly tipped to one side.

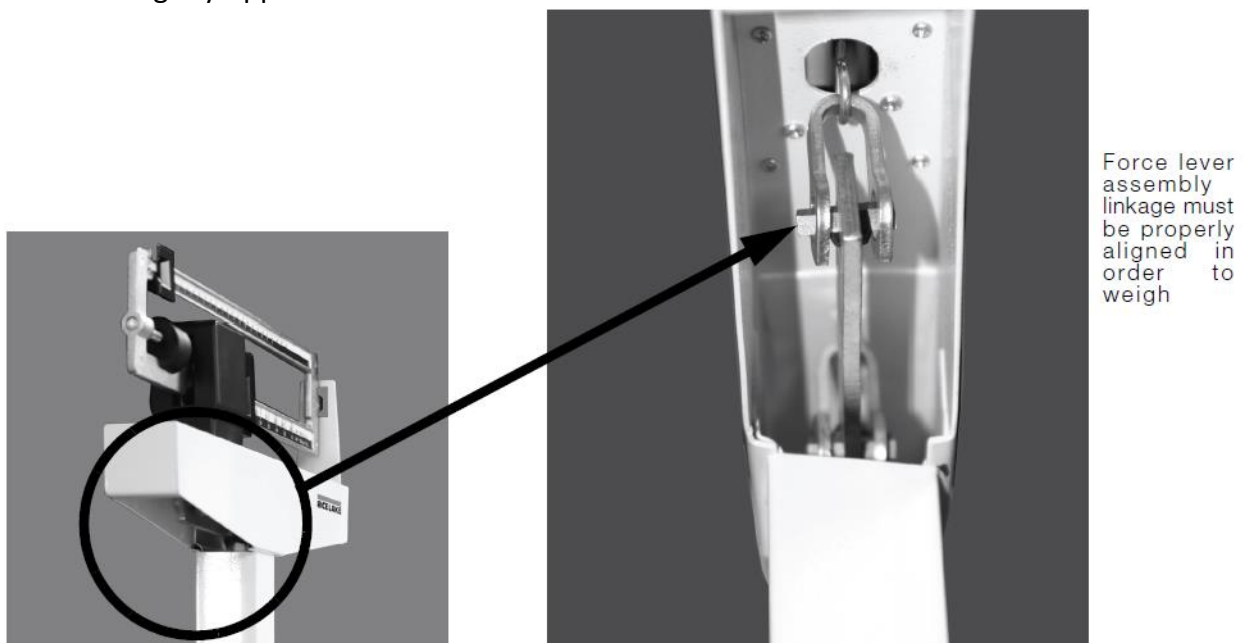

Figure 2-5. View Looking up at Linkage up Underneath the Top Weigh Beam

3. Place the scale upright gently back on the table

▪ **Weigh Platter Installation**

The weighing platter comes separate from the scale base and must be attached for proper operation. To attach the weigh platter to the scale base, use the following instructions.

1. Position the weigh platter on top of the scale platform with the inch/cm marks located next to the pillar as shown in Figure 3-2.
2. Line up the screw holes as shown in Figure 3-1.

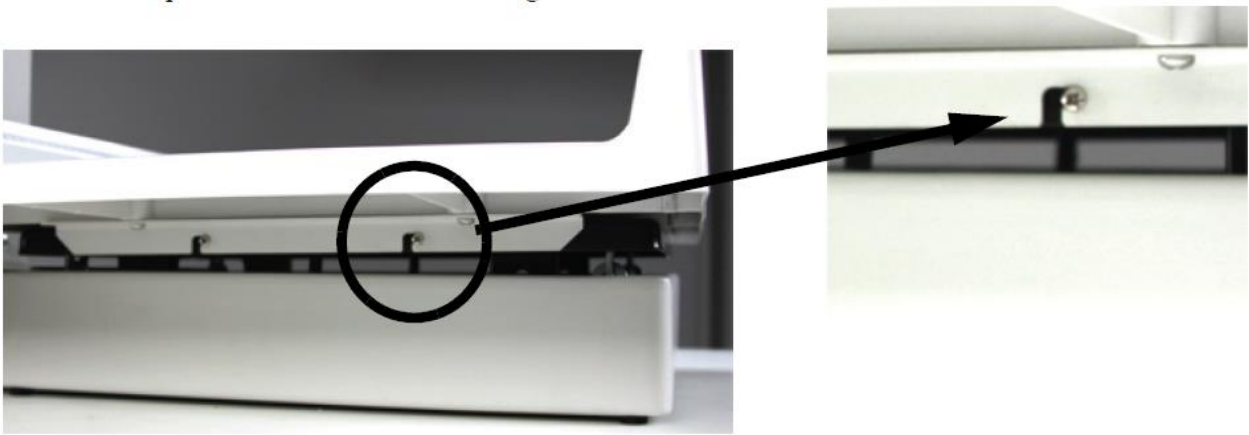

Figure 3-1. Weigh Platter Screw Hole Location

3. Using a Philips head screwdriver, tighten up the four screws to secure it to the scale platform.

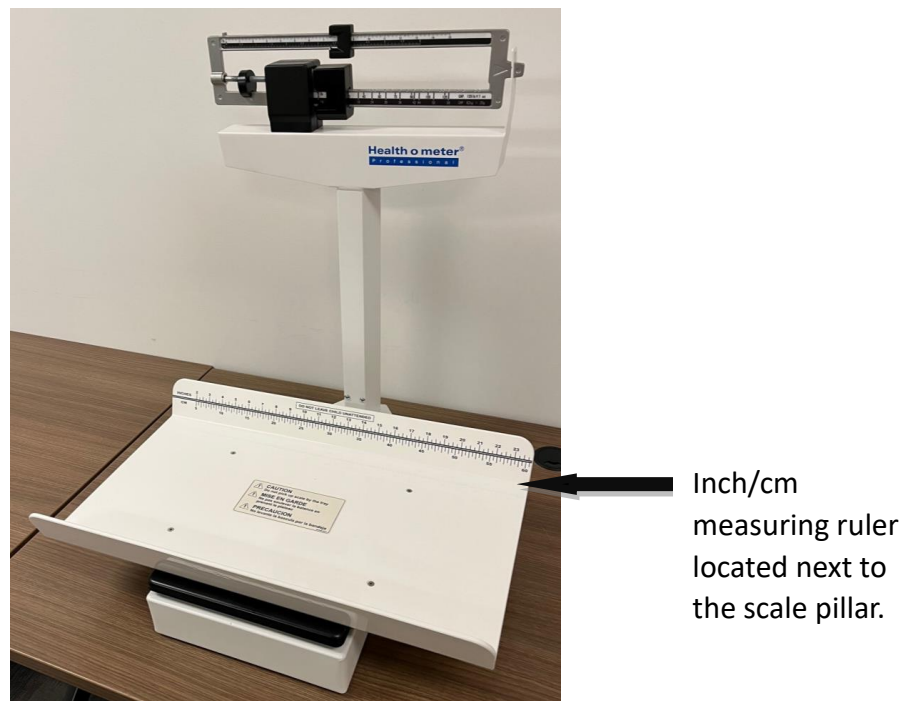

Figure 3-2. Weigh Platter Attached to the Scale Base

Zero Adjustment

To ensure accurate weighments, a zero adjustment should be done to the scale upon arrival and setup. To perform a zero adjustment, perform the following steps.

1. Ensure the scale is sitting upright on a level surface.
2. Make sure that the poise weights are pushed all the way to the left hand side (at zero) making sure that the large poise is firmly seated in the notch and the small poise is firmly against the shoulder of the beam.
3. Check the eye loop area of the scale to ensure that the scale pointer is centered.

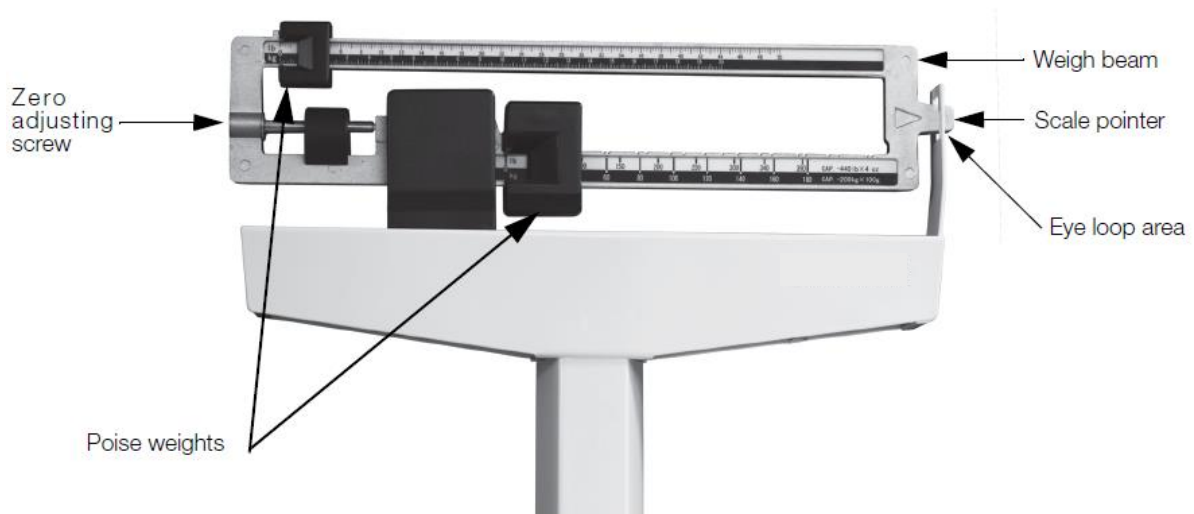

Figure 4-1. Eye Loop Area and Zero Adjusting Screw Location (Lb and kg version shown)

4. If the scale is not balancing properly, then the small zero balance weight must be adjusted. Turn the zero adjusting screw (shown in Figure 4-2) using the enclosed multi-purpose tool. Depending on the direction the zero balance weight will move accordingly.



Figure 4-2. Zero Adjusting Screw Location

Weighing a Baby

To weigh a baby, place the baby on the weigh platter and slide the larger poise (on bottom) to the approximate target weight. Next move the smaller poise on top until the weighing beam balances and the scale pointer is centered within the eye loop area as shown in Figure 4-1.

Troubleshooting

For the most accurate readings, always use the scale on a hard, level surface and stand in the center of the scale platform with the weight evenly distributed. If an error occurs or seems excessive, check the following:

Problem	Possible Solution
Zero balance out of adjustment	<ul style="list-style-type: none"> ▪ The weighing beam must be balanced so the pointer comes to a rest in the center of the eye loop (shown in Figure 4-1) when both poise weights are set at zero (see Figure 4-1 for poise weight location). Adjust the balance by turning the zero adjusting screw at the left end of the weigh beam (see Figure 4-2)
Beam does not move freely	<ul style="list-style-type: none"> ▪ Make sure the pointer is not touching the side of the eye loop, impeding its range of travel. ▪ Visually ensure that the linkage is centered and properly aligned. Occasionally during shipping, the alignment will become skewed. The linkage must be free floating in order for the scale to weigh properly. If the scale is slightly tipped to one side, the linkage can be seen by looking up underneath the top weigh beam.
Platform rocks excessively	<ul style="list-style-type: none"> ▪ Ensure scale is setting on a level surface. When you push down on any corner of the platform, you should not feel any significant rocking.
Beam does not move at all during weighing	<ul style="list-style-type: none"> ▪ Weights are set higher than the person's actual weight. Reset the weights to a lower weight. ▪ Make sure steel rod is properly connected and aligned.
Scale is out of calibration	<ul style="list-style-type: none"> ▪ Recalibrate the scale by placing a known weight on the scale and turning the zero adjustment screw until the pointer remains centered within the eye.

Health o meter®

P r o f e s s i o n a l

This Health o meter® Professional mechanical pediatric scale is intended to be used in a professional medical environment by trained medical staff. This product was designed to weigh patients who are safely positioned on the weighing tray.

To prevent patient/caregiver injury or damage to your scale, please follow the instructions in this user manual very carefully.

- Do not exceed recommended weight limit for this scale.
- Do not transport the scale with a patient or object on the scale.
- To prevent injury, as well as scale damage during assembly, exercise caution when assembling the scale pillar.
- Assemble and operate the scale per the enclosed user instructions.
- For accurate weighing, this scale must be placed on a flat, stable surface.
- For accurate weighing, verify before each use the proper operation according to the procedure described in this manual.
- Do not use in the presence of flammable or explosive materials.
- If the scale becomes damaged, it should not be operated until properly serviced.

Patient/caregiver safety

- This scale is designed for static weighing of patients only. No scale should be used for patient transfer.
- Patient should wear a lightweight covering or a paper tray liner should be used during weighing event.
- To prevent patient injury, the patient must be attended to throughout the entire weighing event.

In no event whatsoever shall Pelstar, LLC be liable for damages or injuries arising from or connected with the assembly, use, or misuse of its products.

Limited Warranty

This Health o meter® Professional scale is warranted from date of purchase against defects of materials or in workmanship for a period of two (2) years. For the complete warranty coverage information visit www.homscales.com.



PELSTAR® , LLC

9500 West 55th St. McCook, IL 60525-7110 USA

1-800-638-3722 or 1-708-377-0600

PLEASE REGISTER YOUR SCALE FOR WARRANTY COVERAGE AT:

www.homscales.com

Health o meter® is a registered trademark of Sunbeam Products, Inc. used under license. Health o meter® Professional products are manufactured, designed, and owned by Pelstar®, LLC. We reserve the right to improve, enhance, or modify Health o meter® Professional product features or specifications without notice.

© Pelstar®, LLC 2025

Please register your scale for warranty coverage at:

www.homscales.com

For User Instructions updates and revisions please go to:

www.homscales.com